

Cavity Barrier Solutions for Brick Slip Systems

Tenmat's VFB Horizontal and VFB Vertical are cavity fire barriers specifically fire tested to offer fire resistance performance within brick slip cladding systems.

Product Description

Tenmat's VFB Horizontals are 'open state' cavity fire barriers for installation horizontally behind brick slip systems, designed to leave a 25mm air gap to allow for drainage and ventilation that is then sealed off in a fire situation.

The VFB Verticals are intumescent cavity fire barriers to be installed vertically behind brick slip systems, designed to be friction fit to the back of the horizontal rails with intumescent capabilities to seal any remaining gaps around rails to the back of the brick slips.

Each VFB Vertical is supplied with 13No. intumescent FF107 Rail Pads that expand to seal the void between the rails and rear of the Brick Slips.

The VFB Horizontals are 3rd party fire tested to ASFP TGD 19 (Fire Resistance Test for 'Open State' Cavity Barriers, whereas the VFB Verticals are tested to EN 1366-4 (Fire Resistance Test for Linear Joint Seals).

Each VFB variant consists of a specially formulated fire rated stone mineral wool section with an integral high expansion intumescent seal fixed to the leading edge.

In a fire situation the intumescent seal rapidly expands to seal off the air gap horizontally and seals vertically around the rails to the back of the brick slips.

Product Details

- 3rd Party Fire Test behind brick slip systems
 - Tests include Ash & Lacy NaturAL-X and Mechslip systems
 - Fire Ratings of min. 90 minutes integrity and min. 30 minutes insulation for cavities up to 395mm
 - Fire Tested on Steel Frame Systems (SFS), concrete, masonry and blockwork inner substrates
 - Maintains a 25mm air gap horizontally
 - Intumescent seals rails in vertical orientation
 - Durability and Age Tested
 - Fixing brackets included as standard
-

Sizes

Horizontal

Thickness (Total Cavity to back of rail less 25mm Air Gap) x 75mm x 1000mm

Vertical

Thickness (Total Cavity to back of rail) x 75mm x 1000mm

Fire Test Evidence

BS EN 1363-1 and to the principles of ASFP TGD19 (horizontal orientation)
EN 1366-4 (vertical orientation)

Inner Leaf Substrate Type (facing cavity) with Appropriate Fire Resistance	Outer Leaf Substrate Type (facing cavity) With Appropriate Fire Resistance	Orientation	Insulation Type Within Cavity (interrupted)	Cavity Width*** (in mm)	Maximum Open State Air Gap (In mm)	Tested Product Reference	Product Fire Resistance Rating	
							Integrity	Insulation
Gypsum based sheathing board on SFS*, Aerated Concrete, Concrete, Blockwork & Masonry	Horizontal Brick Slip (Ash & Lacy NaturAL-X)	Horizontal	Stone Wool**	58-395	25	VFB Horizontal	120	60
Gypsum based sheathing board on SFS*, Aerated Concrete, Concrete, Blockwork & Masonry	Horizontal Brick Slip (Ash & Lacy Mechslip)	Horizontal	Stone Wool**	58-395	25	VFB Horizontal	90	60
Gypsum based sheathing board on SFS*, Aerated Concrete, Concrete, Blockwork & Masonry	Horizontal Brick Slip (Ash & Lacy NaturAL-X & Mechslip)	Vertical	Stone Wool**	Max 395	n/a	VFB Vertical with FF107 Rail Pads	120	30

3rd Party Fire Testing

Fire Test Report 540016A

Fire Test Report 540016B

* Tested sheathing board was Klasse G Board 12.5mm thick, tests included a layer of combustible breather membrane (T200 Thermo Insulating Breather Membrane)

** Tested cavity insulation was Rainscreen Duo Slab insulation, tested range 30-300mm

*** Cavity width is measured from the face of inner substrate to the rear of the brick slip rails

Min. protrusion of cavity barrier in front of cavity insulation must be 8mm or greater

Ash & Lacy NaturAL-X brick slips, 28mm thick, included a rear groove/frog of nominally 12.5mm depth

Ash & Lacy Mechslip brick slips, 28mm thick, which incorporated 14mm deep rear grooves

For vertical applications, 1No. intumescent FF107 Rail Pad must be installed within each horizontal rail centralised in line with VFB Vertical

Technical Information

Colour	Black (VFB Horizontal and VFB Vertical) Red (FF107 Rail Pad)
Finish	Polythene Wrap
Cuttability	Can be cut to length (VFBs only)
Storage	Dry, ambient
Transportation Storage Temperature	-20°C to +70°C
Durability	Type X intended for use in conditions exposed to weather (UV, rain, frost)
Fungal Resistance	Protected by polythene
Smoke/Halogen Content	Low Smoke / Zero Halogen
Minimum Total Working Life (Years)	Based on typical climatic conditions UK 60 years Australia 45 years France 60 years New Zealand 60 years Germany 60 years Hong Kong 40 years The Netherlands 60 years
Dimensional Tolerances (VFBs only)	Thickness +10/-0mm Width +5/-0mm Length +0/-5mm

Working life, durability, halogen content and smoke emission data refers to the active intumescent component.

General Design & Installation Considerations

Maximum free air gap for the VFB Horizontal cavity barrier is 25mm, the space in front of the intumescent strip on the face of the cavity barrier to the rear of the horizontal rails.

The VFB Vertical cavity barrier must be installed to abut the back of the horizontal rails with no clear air gap. It must be ensured that an FF107 Rail Pad is installed within each horizontal rail centralised in line with the VFB Vertical.

Install helping hand brackets as required (to brick slip manufacturer requirements), ensuring that the position of helping hands does not collide with the required position of either the horizontal or the vertical cavity barriers.

Install the VFB Vertical cavity barriers, at the positions required in the fire strategy, ensuring that they are sized to be at least flush finished with top or bottom of the horizontal cavity barriers, the cavity barriers must overlap (the vertical barriers may finish proud of the horizontal cavity barriers, but not shorter). The ends of the vertical cavity barriers must be fitted tightly abutted together, no gaps between the cavity barrier ends are permitted.

Horizontal Open state cavity barriers should be installed in a continuous run, (with the exception of abutting up to the vertical cavity barriers).

Where this is not possible, details should be agreed with the projects principal designer and or fire engineer.

Install the VFB Horizontal cavity barriers, at the positions required in the fire strategy, in-between the vertical cavity barriers, ensuring that any horizontal cavity barriers fitted between vertical cavity barriers are fitted to be at least flush finished with top or bottom of the vertical cavity barriers, the cavity barriers must overlap and be tightly abutted together. The ends of the horizontal cavity barriers must also be fitted tightly abutted together, no gaps between the cavity barrier ends are permitted.

Cavity barriers may be cut to length as required, adjacent lengths must be tightly abutted together.

The intumescent face of the cavity barrier should be unrestricted and free to expand in a fire situation to the back of the rails, it will then be capable of sealing any remaining gaps between the rail and the back of brick slip.

An identification label is attached to the intumescent face of the cavity barrier, ensure this faces out into the open cavity. Also ensure the label is visible and legible and reads the right way up.

Cavity barrier fixing brackets, both multi purpose, (MP bracket) or high performance (HP bracket) must not penetrate through the face of the cavity barrier. Screws for direct fixing and fixings to secure brackets are not supplied by Tenmat.

The brackets used to fix the cavity barriers must be installed with the bracket fixed above and not below the cavity barrier.

The use of tape is not required over the joints between the lengths of cavity barrier, and if used should not be applied over the face of intumescent material.

The cavity barriers must be installed following the installation methods described below. The cavity barriers must not be penetrated by any other mechanical or electrical services.

Fitting Instructions

Horizontal - Fire Barrier Support Details

Cavity Size (mm)	Product Width (mm)	Fitting Option Number	Barrier Support Type	No. of support (brackets) fixings per metre	Maximum (brackets) Centres (mm)
40-100	15-75	1	Screw	N/A	N/A
101-115	76-90	2	MP Bracket	2	500
116-240	91-215	3	MP Bracket	2	500
241-300	216-275	4	MP Bracket	3	350
301-395	276-370	5	HP Bracket	2	500

Vertical - Fire Barrier Support Details

Cavity Size (mm)	Product Width (mm)	Fitting Option Number	Barrier Support Type	No. of support (brackets) fixings per metre	Maximum (brackets) Centres (mm)
40-75	40-75	1	Screw	N/A	N/A
76-90	76-90	2	MP Bracket	2	500
91-395	91-395	3	MP Bracket	2	500

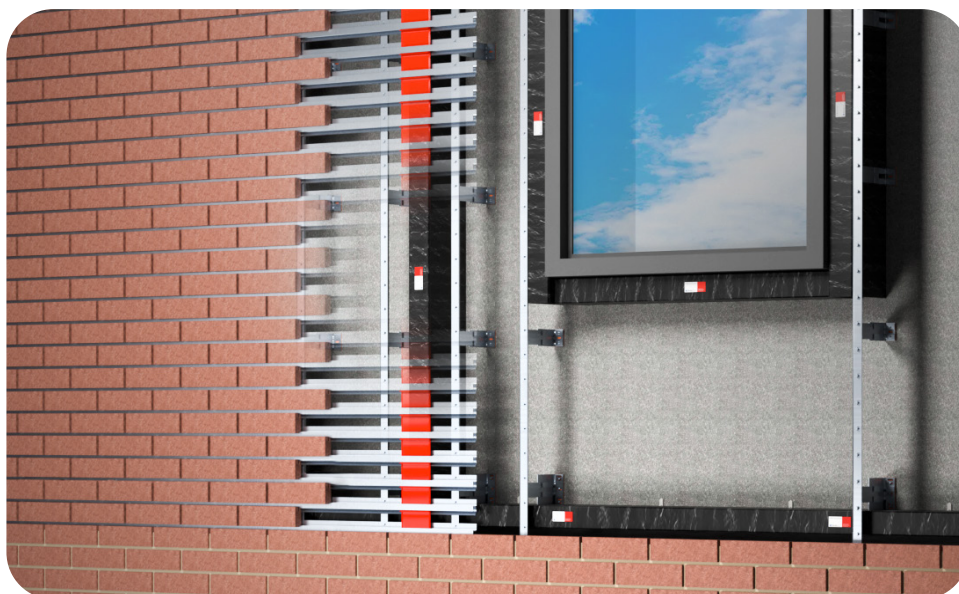

Option 1

VFB HORIZONTAL - Product width across cavity 16mm up to 75mm wide, directly face fixed.

VFB VERTICAL - Product with across cavity 40mm up to 75mm wide, directly face fixed.

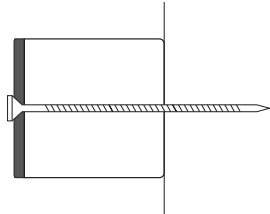

Use stainless steel countersunk head screws, with a maximum head diameter of 16mm and with a length suitable for the size of cavity barrier and sufficient fixing depth into the substrate.

Fixings must have an appropriate fixing depth for the substrate (with a minimum as specified by the fixing manufacturers guidance for their fixing type).

Ensure that the countersunk screw head does not fully penetrate the face of the cavity barrier, the screw head should sit flush or slightly proud.

Care should be taken not to over tighten as this may affect the performance of the intumescent seal.

Horizontal Orientation

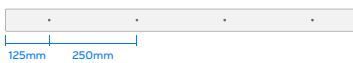

Position the first screw fixing through the centre line of the face of the cavity barrier at a maximum 125mm from one end, continue to face fix through at maximum 250mm centres (4 screws per linear metre), ensuring that the final fixing is a maximum 125mm from the end of the cavity barrier. This will ensure that face fixings are positioned at 250mm centres across the continuous run of cavity barrier.

Vertical Orientation



Cut Sections

It must be ensured that if the cavity barriers are cut to length, sections 200mm or less must have one fixing in place, positioned centrally.

Sections 200 to 500mm must have minimum 2No. fixings in place, 500 to 750mm is 3No. and 750 to 1000mm is 4No. fixings and they must be equally spaced with not more than 250mm between fixings and not more than 125mm for either end.

Slitting

If the intumescent face on the front face of the cavity barrier is slit to allow fitting around vertical rails, it must be ensured that every cut section has face fixings through the face of the intumescent material.

Vertical slits must kept as small as practicable, ensuring no gaps remain and the depth of slit is to minimum the depth of the rail and maximum 10mm deeper than the rail.

Additional face fixings at maximum 125mm to either side of each cut, and ensure that the factory fitted face fixings are no more than 250mm centres from the additional fixings applied.

Suitable face fixings are 65mm long stainless steel woodscrews or pig tail screws.

For VFB HORIZONTAL ensure that the maximum remaining air gap in front of the front face of the cavity barrier to the rear of the rails is 25mm.

For VFB VERTICAL ensure that the cavity barrier abuts the back of the rails.



For installation of FF107 Rail Pad within horizontal rails in conjunction with VFB VERTICAL, see installation instructions at the end of this data sheet.

Option 2

VFB HORIZONTAL - Product width across cavity from 76mm up to 90mm wide, fixed using 2 multi purpose (MP) 65mm brackets (per linear metre).

VFB VERTICAL - Product width across cavity from 76mm up to 90mm wide, fixed using 2 multi purpose (MP) 65mm brackets (per linear metre).

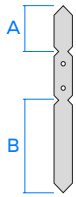

MP brackets are supplied with 2 fixing spikes, one spike is 65mm long (A), the other is 160mm long (B), with a central pre drilled section for securing the bracket to the substrate.

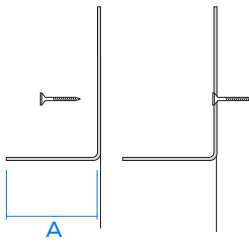

For cavity barriers 76mm-90mm wide (across cavity) use 2 MP brackets and the 65mm (A) long spike.

To secure the bracket use nom. 6mm Ø stainless steel screws/fixings, with a maximum head diameter of 13mm and with a length and type suitable for the substrate. Recommended SFS SX5-5.5 or similar.

Ensure that the screw head sits as flush as possible with the substrate.

Minimum one fixing per bracket.

Fixings must have an appropriate fixing depth for the substrate as specified by the fixing manufacturers guidance for their fixing type.

To help to ensure the cavity barrier sits level once installed, angling the brackets upwards and then lowering the cavity barrier into position can be effective.

Cut Sections

Each metre length of cavity barrier is supplied with 4No. face fixings pre-installed underneath the polythene outer to hold the intumescent strip in place.

It must be ensured that if the cavity barriers are cut to length that sufficient face fixings are in place to hold the intumescent strip to the stonewool backing.

It is not allowable to have any cut sections without a face fixing in place.

For sections 200mm or less, each section must have minimum one face fixing in place, positioned centrally.

Sections 200 to 500mm must have minimum 2No. fixings in place, 500 to 750mm is 3No. and 750 to 1000mm is 4No. fixings and they must be equally spaced with not more than 250mm between fixings and not more than 125mm for either end.

Slitting

If the intumescent face on the front face of the cavity barrier is slit to allow fitting around vertical rails, it must be ensured that every slit section of cavity barrier has face fixings through the face of the intumescent material.

Vertical slits must kept as small as practicable, ensuring no gaps remain and the depth of slit is to minimum the depth of the rail and maximum 10mm deeper than the rail.

Additional face fixings at maximum 125mm to either side of each cut, and ensure that the factory fitted face fixings are no more than 250mm centres from the additional fixing applied.

Suitable face fixings for cut or slit sections are 65mm long stainless steel woodscrews or pig tail screws.

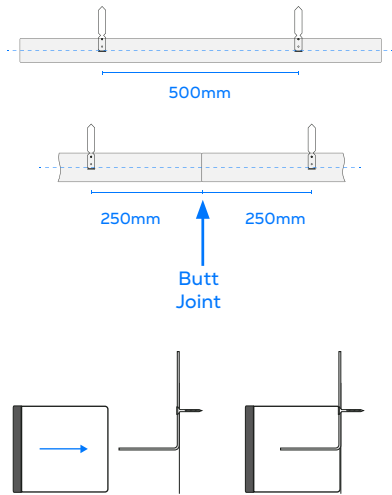

VFB HORIZONTAL

Fix 2 number MP brackets, per linear metre, to the substrate at maximum 250mm from the end of the cavity barrier, with a maximum spacing between brackets of 500mm.

Where sections of cavity barrier are less than 1 linear metre in length, ensure that MP brackets are positioned at a maximum 250mm from each end. For cut sections of cavity barrier less than or equal to 500mm in length only one MP bracket is required.

Push the cavity barrier onto the bracket spike, the brackets should impale the VFB HORIZONTAL to mid barrier depth and must not protrude through the intumescent element.

The cavity barrier should be pushed fully onto the bracket spike and sit flush with the substrate at the rear of the cavity barrier, ensuring that there are no gaps behind the cavity barrier.

The maximum remaining air gap from the front face of the cavity barrier to the back of the rail must be maximum 25mm.

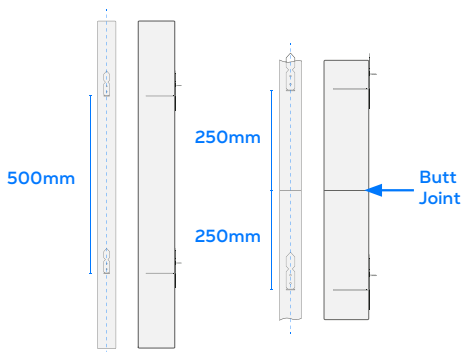

VFB VERTICAL

Fix 2 number MP brackets, per linear metre, to the substrate at maximum 250mm from the end of the cavity barrier, with a maximum spacing between brackets of 500mm.

Where sections of cavity barrier are less than 1 linear metre in length, ensure that MP brackets are positioned at a maximum 250mm from each end. For cut sections of cavity barrier less than or equal to 500mm in length only one MP bracket is required.

Push the cavity barrier onto the bracket spike, the brackets should impale the VFB VERTICAL to mid barrier depth and must not protrude through the intumescent element.

The cavity barrier should be pushed fully onto the bracket spike and sit flush with the substrate at the rear of the cavity barrier, ensuring that there are no gaps behind the cavity barrier.

VFB VERTICAL must be abutting the rear of the horizontal rails.

For installation of FF107 Rail Pad within horizontal rails in conjunction with VFB VERTICAL, see installation instructions at the end of this data sheet.



Option 3

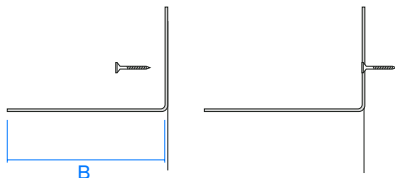
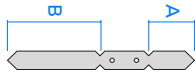

VFB HORIZONTAL - Product width across cavity from 91mm up to 215mm wide, fixed using 2 multi purpose (MP) 160mm brackets (per linear metre).

VFB VERTICAL - Product width across the cavity from 91 up to 395mm wide, fixed using 2 multi purpose (MP) 160mm brackets (per linear metre).

MP brackets are supplied with 2 fixing spikes, one spike is 65mm long (A), the other is 160mm long (B), with a central section for securing the bracket to the substrate.

For cavity barriers 91mm-215mm wide (across cavity) use 2 MP brackets and the 160mm (B) long spike. To secure the bracket use nom. 6mm Ø stainless steel screws/fixings, with a maximum head diameter of 13mm and with a length and type suitable for the substrate. Recommended SFS SX5-5.5 or similar.

Ensure that the screw head sits as flush as possible with the substrate.

Minimum one fixing per bracket required.

Fixings must have an appropriate fixing depth for the substrate (as specified by the fixing manufacturers guidance for their fixing type).

To help to ensure the cavity barrier sits level once installed, angling the brackets upwards and then lowering the cavity barrier into position can be effective.

Cut Sections

Each metre length of cavity barrier is supplied with 4No. face fixings pre-installed underneath the polythene outer to hold the intumescent strip in place.

It must be ensured that if the cavity barriers are cut to length that sufficient face fixings are in place to hold the intumescent strip to the stonewool backing.

It is not allowable to have any cut sections without a face fixing in place.

For sections 200mm or less, each section must have minimum one face fixing in place, positioned centrally.

Sections 200 to 500mm must have minimum 2No. fixings in place, 500 to 750mm is 3No. and 750 to 1000mm is 4No. fixings and they must be equally spaced with not more than 250mm between fixings and not more than 125mm for either end.

Slitting

If the intumescent face on the front face of the cavity barrier is slit to allow fitting around vertical rails, it must be ensured that every cut section has face fixings through the face of the intumescent material.

Vertical slits must kept as small as practicable, ensuring no gaps remain and to minimum the depth of the rail and maximum 10mm deeper than the rail.

Additional face fixings at maximum 125mm to either side of each cut, and ensure that the factory fitted face fixings are no more than 250mm centres from the additional fixing applied.

Suitable face fixings are 65mm long stainless steel woodscrews or pig tail screws.

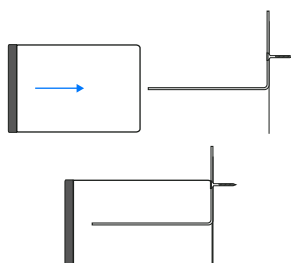
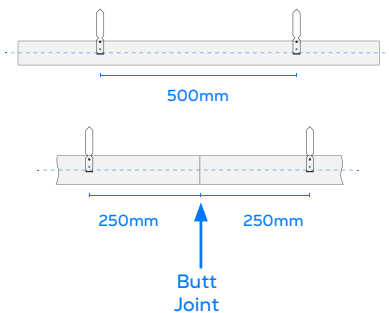

VFB HORIZONTAL

For cavity barriers 91mm-215mm wide (across cavity) use 2 MP brackets and the 160mm long spike. The 160mm spike will require cutting to size, if used in barriers less than 185mm wide, to ensure that the spike does not pierce through the face of the intumescent material, the bracket should be cut to provide a minimum projection through the barrier to 3/4 of the cavity barrier width and to a maximum of 25mm behind the face of the intumescent strip.

Fix 2 number MP brackets, per linear metre, to the substrate at maximum 250mm from the end of the cavity barrier, with a maximum spacing between brackets of 500mm. Where sections of cavity barrier are less than 1 linear metre in length, ensure that MP brackets are positioned at a maximum 250mm from each end. Where the cavity barrier is less than or equal to 500mm in length 1 MP bracket may be used.

Push the cavity barrier onto the bracket spike, the brackets should impale the VFB HORIZONTAL to mid barrier depth and must not protrude through the intumescent element.

The cavity barrier should be pushed fully onto the bracket spike and sit flush with the substrate at the rear of the cavity barrier, ensuring that there are no gaps behind the cavity barrier.

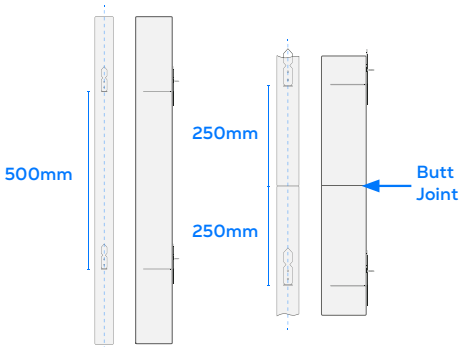

VFB VERTICAL

For cavity barriers 91mm-395mm wide (across cavity) use 2 MP brackets and the 160mm long spike. The 160mm spike will require cutting to size, if used in barriers less than 185mm wide, to ensure that the spike does not pierce through the face of the intumescing material, the bracket should be to a maximum of 25mm behind the face of the intumescing strip.

Fix 2 number MP brackets, per linear metre, to the substrate at maximum 250mm from the end of the cavity barrier, with a maximum spacing between brackets of 500mm. Where sections of cavity barrier are less than 1 linear metre in length, ensure that MP brackets are positioned at a maximum 250mm from each end. Where the cavity barrier is less than or equal to 500mm in length 1 MP bracket may be used.

Push the cavity barrier onto the bracket spike, the brackets should impale the VFB VERTICAL to mid barrier depth and must not protrude through the intumescent element.

The cavity barrier should be pushed fully onto the bracket spike and sit flush with the substrate at the rear of the cavity barrier, ensuring that there are no gaps behind the cavity barrier.

For installation of FF107 Rail Pad within horizontal rails in conjunction with VFB VERTICAL, see installation instructions at the end of this data sheet.



Option 4

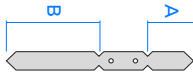

VFB HORIZONTAL - Product width across cavity from 216mm up to 275mm wide, fixed using 3 multi purpose (MP) 160mm brackets per linear metre).

VFB VERTICAL - See Option 3

MP brackets are supplied with 2 fixing spikes, one spike is 65mm long, the other is 160mm long, with a central section for securing the bracket to the substrate.

For cavity barriers 216mm-275mm wide (across cavity) use 3 MP brackets and the 160mm (B) long spike. To secure the bracket use nom. 6mm Ø stainless steel screws/fixings, with a maximum head diameter of 13mm and with a length and type suitable for the substrate. Recommended SFS SX5-5.5 or similar.

Ensure that the screw head sits as flush as possible with the substrate.

Minimum one fixing per bracket required.

Fixings must have an appropriate fixing depth for the substrate (as specified by the fixing manufacturers guidance for their fixing type).

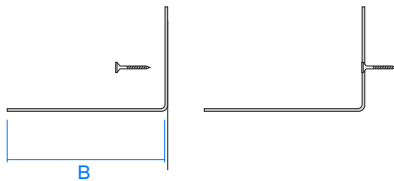

To help to ensure the cavity barrier sits level once installed, angling the brackets upwards and then lowering the cavity barrier into position can be effective.

Cut Sections

Each metre length of cavity barrier is supplied with 4No. face fixings pre-installed underneath the polythene outer to hold the intumescent strip in place.

It must be ensured that if the cavity barriers are cut to length that sufficient face fixings are in place to hold the intumescent strip to the stonewool backing.

It is not allowable to have any cut sections without a face fixing in place.

For sections 200mm or less, each section must have minimum one face fixing in place, positioned centrally.

Sections 200 to 500mm must have minimum 2No. fixings in place, 500 to 750mm is 3No. and 750 to 1000mm is 4No. fixings and they must be equally spaced with not more than 250mm between fixings and not more than 125mm for either end.

Slitting

If the intumescent face on the front face of the cavity barrier is slit to allow fitting around vertical rails, it must be ensured that every cut section has face fixings through the face of the intumescent material.

Vertical slits must kept as small as practicable, ensuring no gaps remain and to minimum the depth of the rail and maximum 10mm deeper than the rail.

Additional face fixings at maximum 125mm to either side of each cut, and ensure that the factory fitted face fixings are no more than 250mm centres from the additional fixing applied.

Suitable face fixings are 65mm long stainless steel woodscrews or pig tail screws.

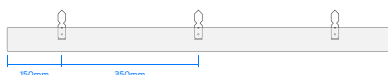

VFB HORIZONTAL

For cavity barriers 216-275mm wide (across cavity) use 3 MP brackets and the 160mm long spike.

Fix 3 number MP brackets, per linear metre, to the substrate at maximum 150mm from the end of the cavity barrier, with a maximum spacing between brackets of 350mm. Where sections of cavity barrier are less than 1 linear metre in length, ensure that MP brackets are positioned at a maximum 150mm from each end. Where the cavity barrier is less than or equal to 350mm in length 1 MP bracket may be used.

Push the cavity barrier onto the bracket spike, the brackets should impale the VFB HORIZONTAL to mid barrier depth and must not protrude through the intumescent element.

The cavity barrier should be pushed fully onto the bracket spike and sit flush with the substrate at the rear of the cavity barrier, ensuring that there are no gaps behind the cavity barrier.

The maximum remaining air gap from the front face of the cavity barrier to the back of the rail must be maximum 25mm.

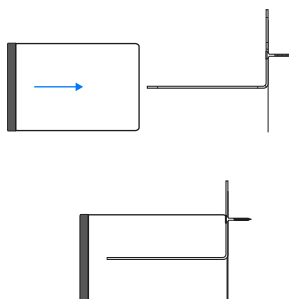

Option 5

VFB HORIZONTAL - Product width across cavity from 276mm-370mm wide, fixed using 2 high performance (HP) 328mm brackets (per linear metre).

VFB VERTICAL - See Option 3

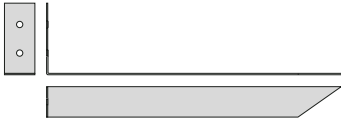

HP brackets are supplied with a single fixing spike, at 328mm long with a 90° return angle for securing the bracket to the substrate.

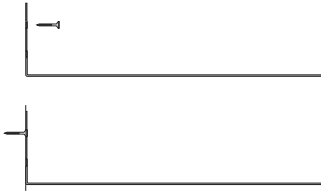

The 328mm spike will require cutting to size, if used in barriers less than 350mm wide, to ensure that the spike does not pierce through the face of the intumescent material.

The bracket should be cut to provide a minimum projection through the barrier to 3/4 of the cavity barrier width and to a maximum of 25mm behind the face of the intumescent strip.

To secure the bracket use nom. 6mm Ø stainless steel screws/fixings, with a maximum head diameter of 13mm and with a length and type suitable for the substrate. Recommended SFS SX5-5.5 or similar.

Ensure that the screw head sits as flush as possible with the substrate.

Minimum one fixing per bracket required.

Fixings must have an appropriate fixing depth for the substrate (as specified by the fixing manufacturers guidance for their fixing type).

To help to ensure the cavity barrier sits level once installed, angling the brackets upwards and then lowering the cavity barrier into position can be effective.

Cut Sections

Each metre length of cavity barrier is supplied with 4No. face fixings pre-installed underneath the polythene outer to hold the intumescent strip in place.

It must be ensured that if the cavity barriers are cut to length that sufficient face fixings are in place to hold the intumescent strip to the stonewool backing.

It is not allowable to have any cut sections without a face fixing in place.

For sections 200mm or less, each section must have minimum one face fixing in place, positioned centrally.

Sections 200 to 500mm must have minimum 2No. fixings in place, 500 to 750mm is 3No. and 750 to 1000mm is 4No. fixings and they must be equally spaced with not more than 250mm between fixings and not more than 125mm for either end.

Slitting

If the intumescent face on the front face of the cavity barrier is slit to allow fitting around vertical rails, it must be ensured that every cut section has face fixings through the face of the intumescent material.

Vertical slits must kept as small as practicable, ensuring no gaps remain and to minimum the depth of the rail and maximum 10mm deeper than the rail.

Additional face fixings at maximum 125mm to either side of each cut, and ensure that the factory fitted face fixings are no more than 250mm centres from the additional fixing applied.

Suitable face fixings are 65mm long stainless steel woodscrews or pig tail screws.

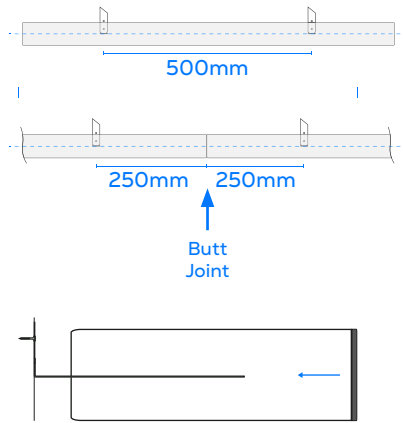

VFB HORIZONTAL

Fix 2 number HP brackets, per linear metre, to the substrate at maximum 250mm from the end of the cavity barrier, with a maximum spacing between brackets of 500mm.

Where sections of cavity barrier are less than 1 linear metre in length, ensure that MP brackets are positioned at a maximum 250mm from each end. Where the cavity barrier is less than or equal to 500mm in length 1 HP bracket may be used.

Push the cavity barrier onto the bracket spike, the brackets should impale the VFB HORIZONTAL to approximately mid barrier depth and must not protrude through the intumescent element. The cavity barrier should be pushed fully onto the bracket spike and sit flush with the substrate, at the rear of the cavity barrier, ensuring that there are no gaps behind the cavity barrier.

Fitting Instructions

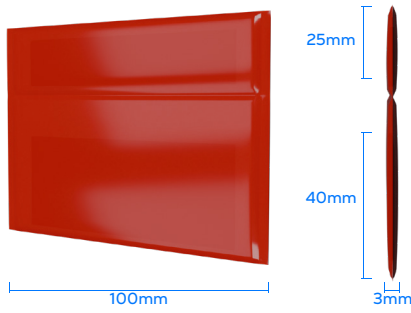

The FF107 Rail Pad consists of two intumescent strips.

The upper strip is 3x25x100mm.

The lower strip is 3x40x100mm.

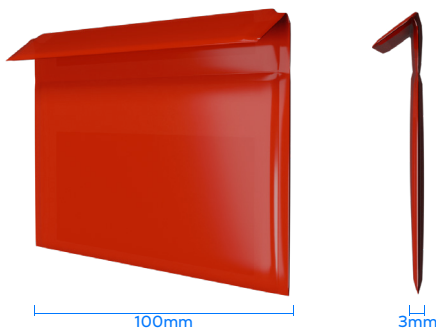

Fold the upper 25mm wide strip in half lengthways to form an upside down V or U shape.

Ensure lower strip is positioned to the bottom of the polythene sleeve.

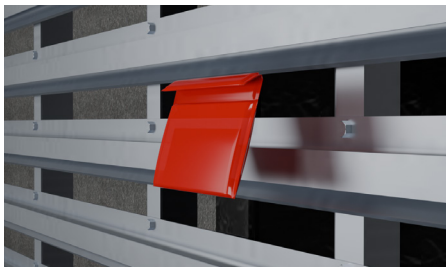

Insert the folded upper strip into the upper rails so that it sits into the top edge and rear of the upper rail.

Insert the lower pad to sit directly on top of the lower rail.



Ensure the upper strip stays positioned up into the upper rail.

Ideally the lower strip should sit back to the lower rail, however the brick slip will move this into position once fitted.

Ensure the lower intumescent pad is set to the bottom, if it is positioned too high it could restrict the fitting of the brick slips.

Fitting Instructions

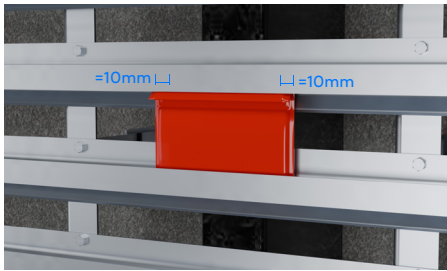

Ensure that the FF107 Rail Pad is centralised in line with the VFB VERTICAL that sits tightly up to the back of the horizontal rails.

I.e. nominally 10mm of the intumescent strips in the FF107 Rail Pad should protrude past either side of the VFB VERTICAL.



An FF107 Rail Pad must be fitted into each horizontal rail that crosses the VFB VERTICAL cavity barrier location.



Ensure the pad is located into the upper rail and sat on the lower rail prior to fitting the brick slip in position.

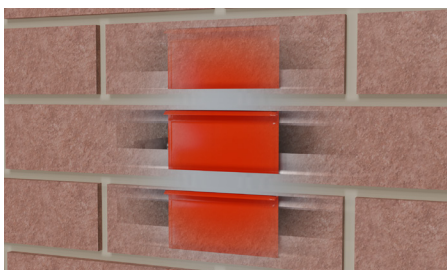

If installed correctly into the upper rail, the brick slips can be installed as normal.

If a brick slip is difficult to insert, check the upper strip of the FF107 Rail Pad is inserted in the top and rear of the upper rail only and the lower intumescent strip is sat down on the lower rail not blocking the path for the brick slip to be lifted up into the rail.

Cavity Barrier Solutions for Brick Slip Systems

Tenmat Ltd.
Northbanks Industrial Park,
Irlam, Frank Perkins Way,
Greater Manchester,
M44 5EW

+44 161 872 2181
fpsales@tenmat.com

tenmat.com



Advanced materials.
tenmat.com



Part of the
Diamorph Group

Tenmat warrants the materials it produces will conform to Tenmat specifications and approved drawings where applicable. It is entirely the customer's responsibility to make the final product choice and satisfy themselves of the suitability of the product for the intended application, carrying out testing where required. For construction projects, all products which the customer is intending to use on a particular project must be approved in writing by the customer's building designer, system designer or design control professional, to ensure compliance with the latest regulations.

The information contained in Tenmat data sheets is presented in good faith. Tenmat Limited makes passive fire protection product suggestions based solely upon and limited to the information made available to Tenmat. Tenmat possesses knowledge of fire test data and offers manufacturers installation advice. Within reason, Tenmat is skilled at offering opinion concerning the installations in question, and can comment on interfaces with other construction materials, but this is not a recommendation or decision. Decisions on overall building fire strategy are not made by Tenmat. Tenmat products have been tested for a wide range of construction types, and they must be only used in accordance with Tenmat test evidence. Each specific Tenmat product must be installed into a construction that matches the corresponding test report. Tenmat product performance requires safe and proper handling and correct installation.