

# Decanter Centrifuge fitted with FEROBIDE tiles

## Wear Performance

The typical results for FEROBIDE in ASTM G65 tests is 3mm<sup>3</sup> of wear, comparable to that of tungsten carbide.

When compared to other common wear resistant materials in sliding abrasion, FEROBIDE is:

- 15 times better than 500 HB hardened steels,
- 8-10 times better than chromium carbide plates and hard face welds,
- 6 times better than cast white iron,
- 4 times better than 97% alumina.

---

## Welding

Welding Ferobide creates a strong joint, capable of reaching 360 MPa shear strength which is stronger than a typical braze joint. Welding Ferobide maintains hardness of host metal, with a minimal heat affected zone. By maintaining hardness of the underlying steel, the wear resistance of the entire system is ensured. Ferobide is a very cost effective product when used and welded correctly.

Below are some guidelines to assist you:

- MIG/stick weld, 120 amps, dissimilar wire/rod gives best result.
- Clamp tile down when tacking, if one end curls up the tile will crack.
- Tack in the middle of tile length if needed, weld outwards from the middle.
- Don't hesitate when welding, so as to avoid heat build up.
- Do no quench after welding.
- Maintain a maximum tile overhang from the flight of 2x the tile thickness.

# Wear Resistant Materials for Decanter Centrifuges

## Product Description

For scroll flight protection, our weldable tungsten carbide composite material FEROBIDE is the ideal solution as it allows for direct welding to the scroll using conventional welding methods with no need for an intermediate “carrier” as conventional tungsten carbide tiles do. Since there is no need for a carrier, FEROBIDE tiles have a larger wear resistant surface area, protecting more of the scroll.

FEROBIDE is quickly installed directly to the scroll via a secure weld. This unique design allows it to be fitted to any scroll configuration.

Compared to hardfacing options, welding tiles is a quicker operation.

Through its increased impact strength and weld joint bonding strength, FEROBIDE avoids internal damage caused by chipping and breakage.

For feed and discharge port liners, our fine-grained reaction bonded silicon carbide material REFEL offers hard wearing performance together with a chemical inertness to ensure a long life and good wear protection to the surrounding steel structure. REFEL is also used as bowl wear strips.

## Customer Benefits

- Save money
- Protect vital parts from wear
- Fit to any centrifuge scroll design
- Quick, easy to install with reliable weld
- Higher strength of weld joint avoids tile delamination
- Higher impact strength avoids internal damage

## Applications

- Decanter centrifuge flight tiles
- Feed and discharge port liners
- Wear strips for bowls

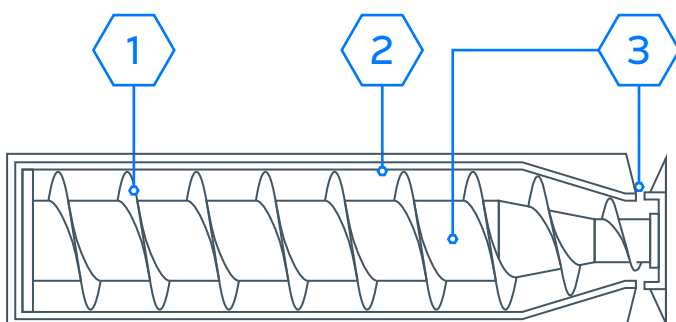

- 1 FEROBIDE scroll flight tiles
- 2 REFEL bowl wear strips
- 3 REFEL feed and discharge port liner